

Simultaneous Thermal Analyzer **STA**

Thermogravimetry-Differential Scanning Calorimeter TG-DSC



High Precision × Stability × Automation
Authentic, Reliable TG-DSC



Rigaku

POWERING NEW PERSPECTIVES

A New Generation of TG-DSC in a Different Class

STAvesta

The long-awaited new STA model, STAvesta, is here—offering all the features you wanted, the precision you need, and dependable stability—all in one instrument.



All six furnace types can be swapped effortlessly without interference from attachments. Features include reduced oxygen concentration, a newly developed automatic adjustment mechanism, and thermal homogenization of the furnace body—all contributing to highly accurate and reliable quantitative measurements. Designed to support all users, from beginners to experts.



ASC – Automatic Sample Changer Handles up to 52 samples

You can load up to 52 measurement samples (including 4 calibration samples) and 3 reference samples. With capacity for up to 1,000 consecutive runs, this greatly enhances automation and throughput. Compatible with all furnace types. The top-mounted design saves bench space.

Standard gas flow designed tray section reduces atmospheric exposure—highly effective for testing moisture-sensitive powders.

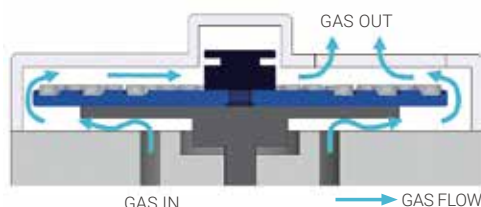

Real-Time Sample Observation

Capture image data not available with conventional thermal analysis, such as shape and color changes. This visual insight accelerates and enhances both R&D speed and quality.

(See P. 8 for more details)

Experience the Assurance of vestaeye Self-Diagnostic Functionality

STAvesta comes standard with the industry-first self-diagnostic feature "vestaeye."

Before starting measurements, the device checks for any abnormalities, ensuring that it is operating normally. This allows you to use the device with peace of mind, knowing that any abnormalities will be detected early.



Features of vestaeye

- Self-diagnosis begins upon device startup, ensuring peace of mind even during measurement initiation.
- Avoid sample loss due to errors during the process by detecting anomalies before starting measurements.
- Verify the device's normal operation before executing measurements after a period of inactivity or prior to nighttime operations.
- Identify specific areas of concern when abnormalities occur in the device.
- When anomalies occur in the device, generate field support reports with just one click.
- Achieve seamless service support through clear identification of device status.

Interchangeable Furnaces—Six Types

The STAvesta can accommodate a range of furnaces* in one unit, enabling flexible operation for diverse thermal analysis needs:



*Furnace material: Alumina

Airtight, Optimized Furnace & Balance Chamber

Enhanced sealing and gas tubing design. Inert gas enters via the Middle Gas Port and flows both the furnace and balance chambers—preventing residual oxygen in the balance chamber from reaching the sample. Allows rapid reduction of oxygen concentration around the sample using minimal gas.

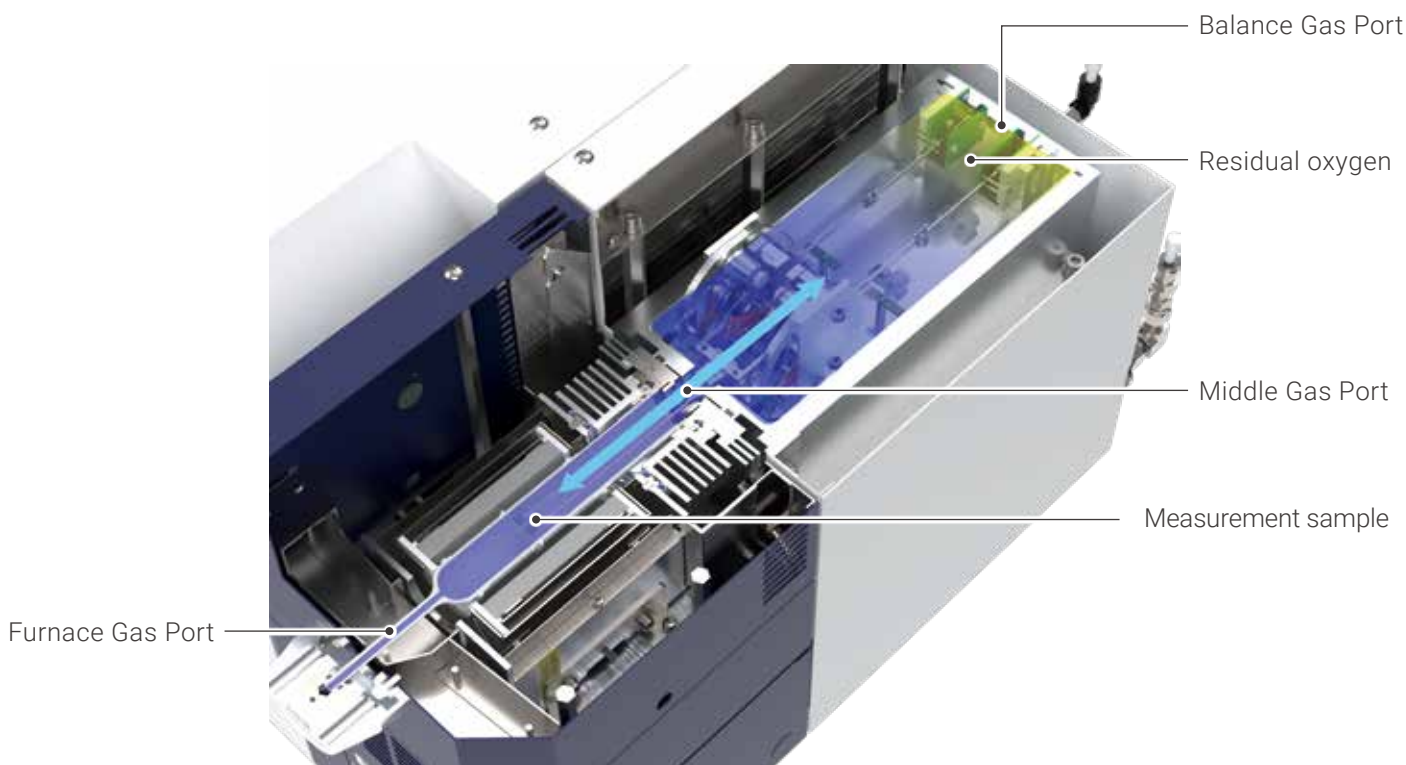

Oxygen Concentration Change

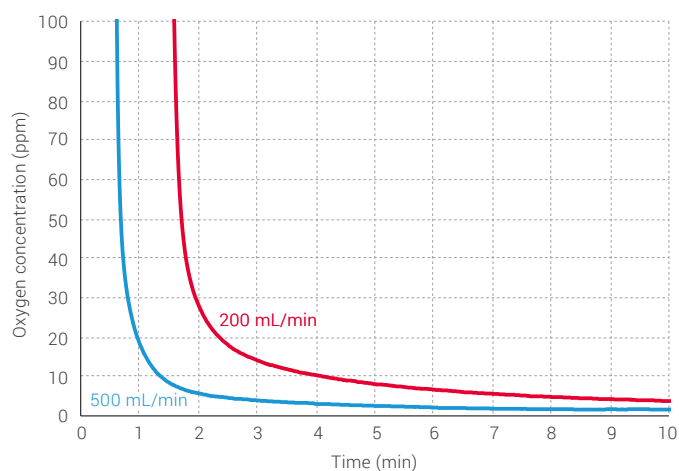

The start of gas flow under ambient conditions after system startup is defined as 0 min.

Instrument: STAvesta/B (with Oxygen reducing set)

Gas purity: 99.9995%

Gas tubing: From gas cylinder to Middle Gas Port: metal tubing

From Balance Gas Port to Oxygen reducing set: polyurethane tubing

Application Measurement of iron under an inert atmosphere

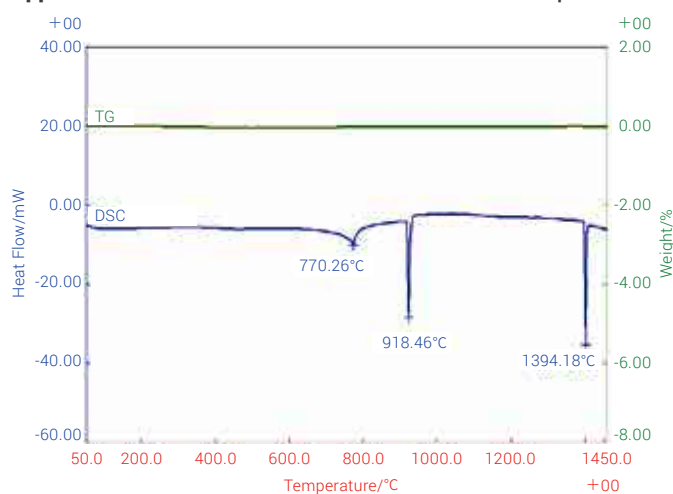

Sample: Fe, 30 mg

This result shows the measurement of high-purity iron (99.99%) under Ar atmosphere.

In the DSC signal, a Curie point is observed near 770°C, and phase transitions involving crystal structure changes are seen around 918°C and 1,394°C. The TG signal shows no mass change (i.e., no oxidation), indicating that the STAvesta provides a low-oxygen measurement environment thanks to its highly airtight design.

Isothermal Unit That Greatly Improves Baseline Stability

By incorporating an isothermal unit inside the protection tube of the electric furnace*, the heat distribution around the sample is made more uniform. This effectively suppresses heat transfer by radiation and the influence of convection. As a result, baseline stability is significantly improved, enabling more accurate and reliable quantitative measurements.

*Compatible furnace types: Standard furnace S, High temperature furnace H, Indirect heated furnace B



Temperature resolution evaluation

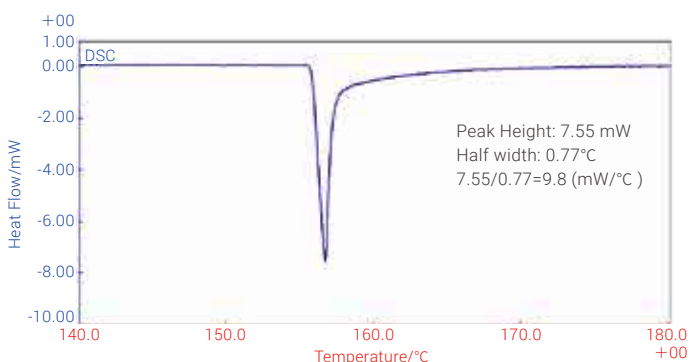

Sample: Indium, 1 mg (Al, 5 mmh open pan)
Heat. rate: 20° C/min

Energy accuracy (σ/ave)

Energy (J/g)	
Meas.1	28.594
Meas.2	28.48
Meas.3	28.361
Meas.4	28.585
Meas.5	28.641
Meas.6	28.448
Meas.7	28.467
Meas.8	28.349
Meas.9	28.444
Meas.10	28.402
AVE	28.504
MAX	28.769
σ	0.129
σ/AVE	0.454%

Sample: Indium, 10 mg (crimped pan)
Reference: empty (crimped pan)
Instrument: STAvesta/H
(with Isothermal unit)

Application Decarbonation Reaction of Calcium Carbonate ($CaCO_3$)

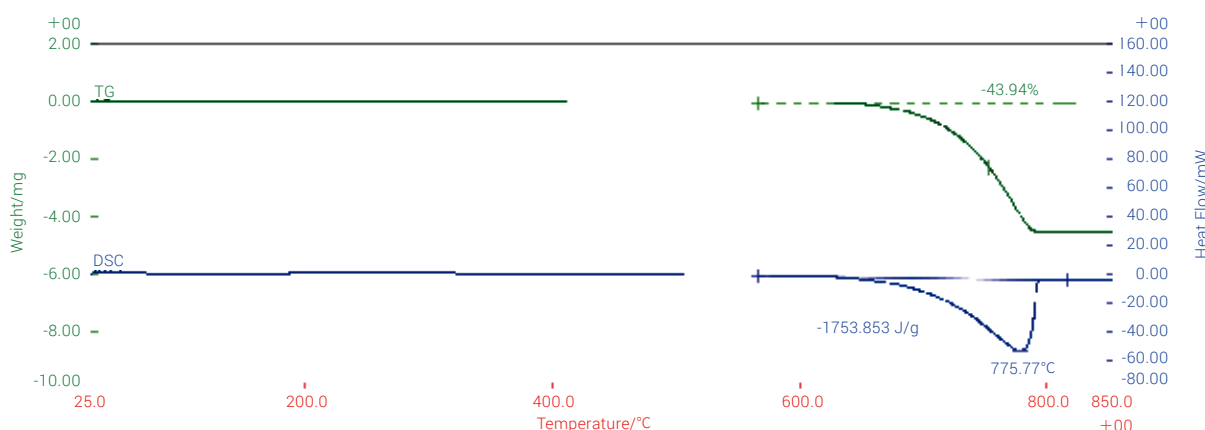

Sample: $CaCO_3$, 10 mg

This example shows the mass loss and endothermic reaction caused by CO_2 release from calcium carbonate. The stable baseline enables accurate measurement of both mass change and heat flow.

Smart Baseline Drift Correction Balancing Reliability and Efficiency

STAvesta adopts a horizontal differential balance configuration with TG baseline reproducibility of less than 10 µg. In addition, the innovative FlatBlank function automates baseline adjustment. It corrects data intelligently to achieve a “flat baseline” without manual intervention. Even during continuous measurements using the ASC, no individual blank measurements are required. Corrections are automatically applied before measurement begins, allowing seamless transition into continuous operation—eliminating the time-consuming manual adjustments of the past.

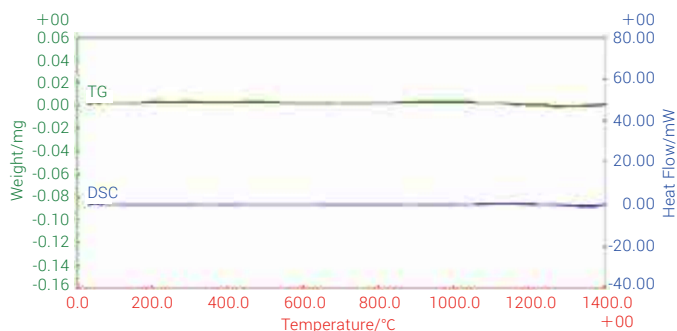

Instrument: STAvesta/H(with isothermal unit), FlatBlank function executed
 Sample pan: Al₂O₃, 2.5 mmh empty pan
 Temp. range: Room temperature to 1,400° C
 Heat. rate: 20° C/min

Application Detecting minute mass changes in PET

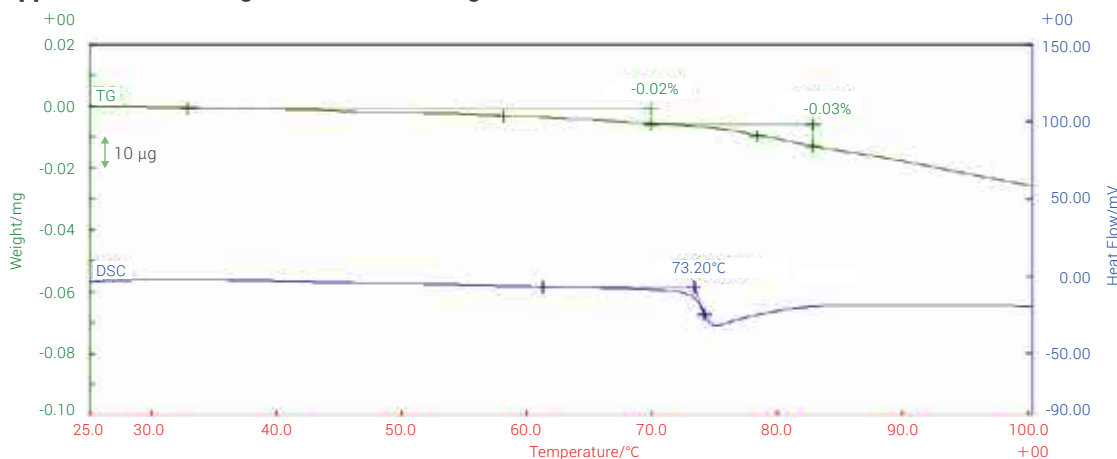

Sample: PET pellet, 25 mg

This example shows measurement results of polyethylene terephthalate (PET) under an air atmosphere. About 10 µg of total mass loss was detected, attributed to two events: volatilization of components between 30° C to 70° C, and minor gas release associated with the glass transition between 70° C to 85° C.

Exceptional Temperature Control Performance Rapid Control + Advanced Control

The newly developed, patented Rapid Control feature enables precise tracking of the programmed reference temperature, dramatically improving the sample temperature’s responsiveness.

When combined with the newly introduced Advanced Control (Mode 2), the temperature profile more closely follows the ideal heating curve.

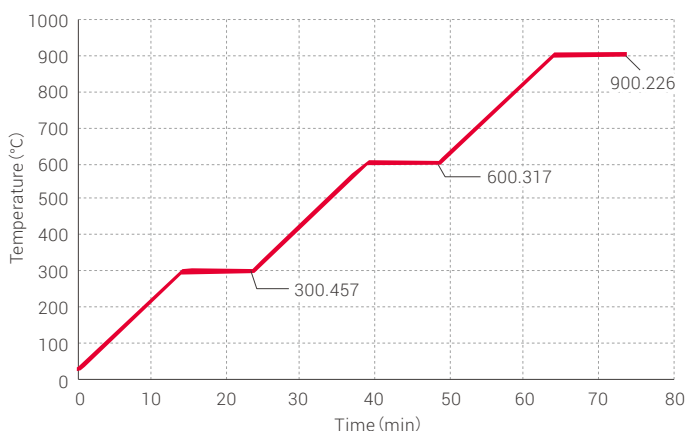

Hold examples at 300°C, 600°C, and 900°C

Instrument: STAvesta/H, Advanced Control (Mode 2) executed
 Heat. rate: 20° C/min, 10 min hold

Easy Sample Holder Replacement

The plugin-type sample holder simplifies replacement. Maintenance is easy, even in the event of sample overflow. The holder's position can also be visually confirmed through the upper window above the balance for added safety and convenience.

After replacement, FlatBlank automatically adjusts the baseline, allowing immediate and accurate measurements without additional steps.



Rapid Post-Measurement Cooling

After measurement, an integrated cooling fan automatically brings the system back to room temperature. Cooling from 1,000°C to 50°C takes less than 15 minutes, supporting high-throughput operation.

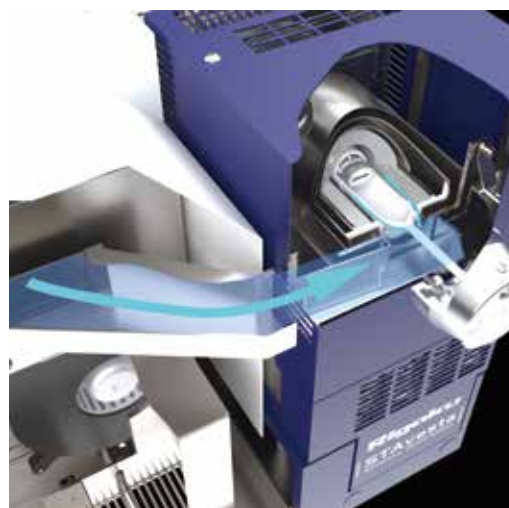
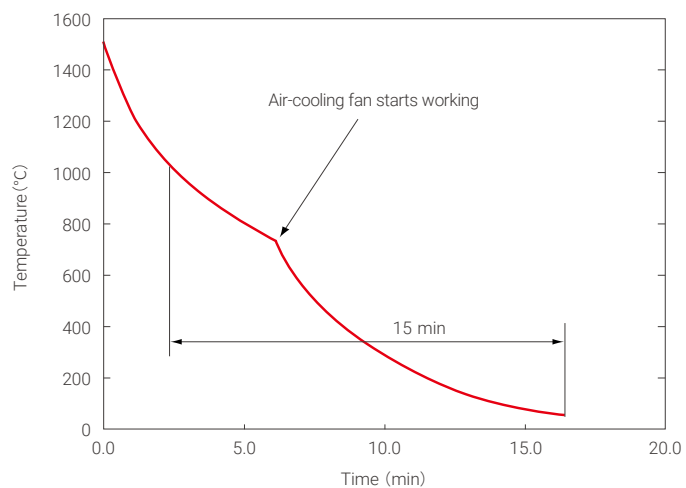

Flexible Gas and Environment Control

By connecting the 2ch-FLOW COMPO Jr., flow control of up to six different gases synchronized with the temperature program becomes possible. Additional units can also be installed after purchase to accommodate future application needs.

Sample Observation STA

STAvesta/C

Real-time observation of sample change



Any sample changes during measurement can be observed as they happen. The analysis results and sample images can be studied together, leading to new insights.

- Records the sample images clearly during measurement up to 1,000°C
- Ensures visibility with the devitrification protection unit
- Real-time observation of changes in sample shape during heating
- Corresponds with ASC's continuous measurement

Devitrification Prevention Unit for Protection Tube



Gases released during sample decomposition can cause devitrification or contamination of the quartz glass protection tube, resulting in blurred observation images. By installing the devitrification prevention unit, only the replaceable devitrification prevention plate—mounted inside the protection tube—is exposed to the gas, allowing the quartz protection tube to remain in use. This helps simplify maintenance and reduce overall measurement costs.

Application Thermal behavior of disaccharide hydrate

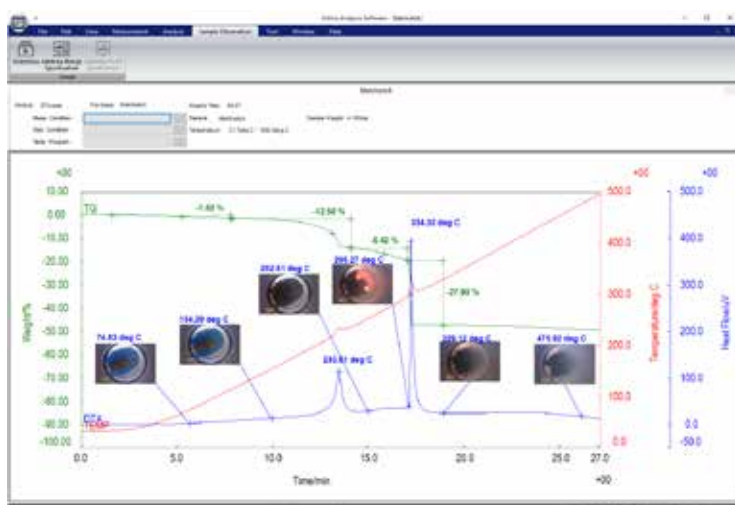
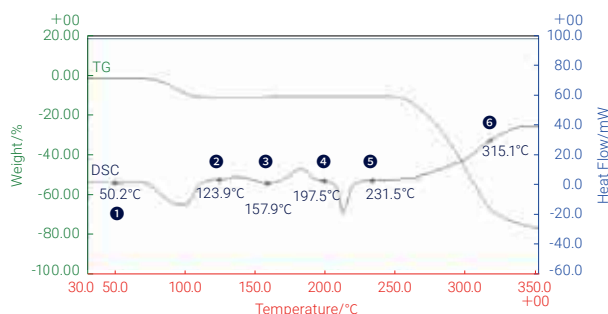

Compatible with Various Options

The unit can be installed alongside other options such as the ASC and evolved gas introduction interface, without interference.

Easy Installation

Easily mountable onto the standard configuration of the STAvesta system.

You can watch example videos of measurements with the sample observation unit here

<https://rigaku.com/products/thermal-analysis/sta/stavesta-sample-observation>



Humidity-Controlled STA

STAvesta/HUM-1

Easy TG-DSC Measurements in Water Vapor Atmosphere



STAvesta/HUM-1 combines a simultaneous thermal analyzer with a steam generator, enabling TG-DSC measurements under water vapor atmosphere.

It employs a polymer-type relative humidity sensor and a high-precision temperature sensor to provide fast response and long-term stability in steam concentration control.

Compatible with ASC.

STAvesta/HUM-1 system configuration diagram

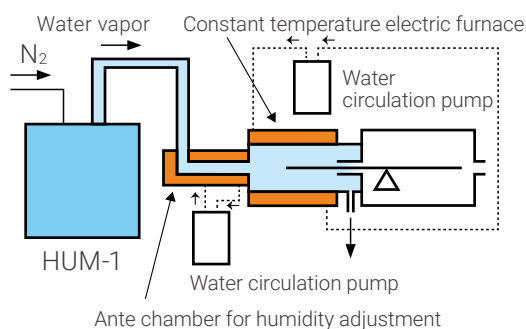

Application

Mass changes in α -cyclodextrin associated with change in controlled humidity

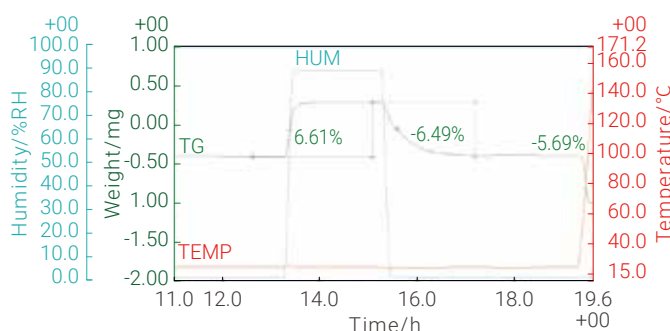

When the relative humidity changed from 25° C dry to 25° C 90% RH, a 6.6% mass increase is observed. 6.5% mass loss is observed when RH is returned to dry conditions. When the sample was re-heated in dry conditions, 5.7% mass loss is observed.

Refrigerated Cooling STA

STAvesta/LR

Enables low-temperature measurements from -40°C and controlled cooling beyond conventional limits



In gas adsorption studies using CO_2 and similar gases, lower temperatures generally increase the amount of gas adsorbed. Therefore, measurements below room temperature are often required. STAvesta/LR meets this need by enabling evaluation from as low as -40°C , making it possible to analyze gases that are difficult to adsorb at room temperatures and to more accurately assess the performance of adsorbent materials.

The unit also allows heating up to 700°C , making it suitable for pretreatment processes such as gas desorption from materials. By utilizing programmable heating and cooling sequences, both pretreatment and adsorption/desorption analysis can be performed in a single continuous run.

In addition, the optional automatic sample changer allows for automated, continuous measurement of multiple samples.

Separated-Type TG-DTA

TG-DTA8122 with Separate Controller

Flexible installation with separate balance and controller units



The separated design allows the balance and control unit to be installed independently, offering greater installation flexibility—including use inside a glove box.

Compatible with automatic sample changer and sample observation furnace configurations.

Image of Installation in a glove box

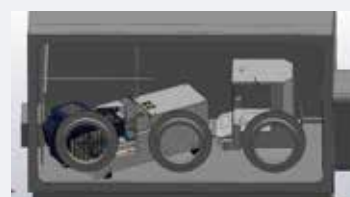

Temperature Modulation Measurement

Dynamic STA

This technique applies sinusoidal modulation to the conventional constant-rate heating program, enabling new modes of thermal analysis. With this function, specific heat capacity (Cp) measurements can be performed up to a maximum of 1500°C.*1

Dynamic DSC with TG-DSC

Sample: Silica (SiO₂) powder, Heating rate: 5° C/min, Modulation period: 60 seconds, Amplitude: 2° C

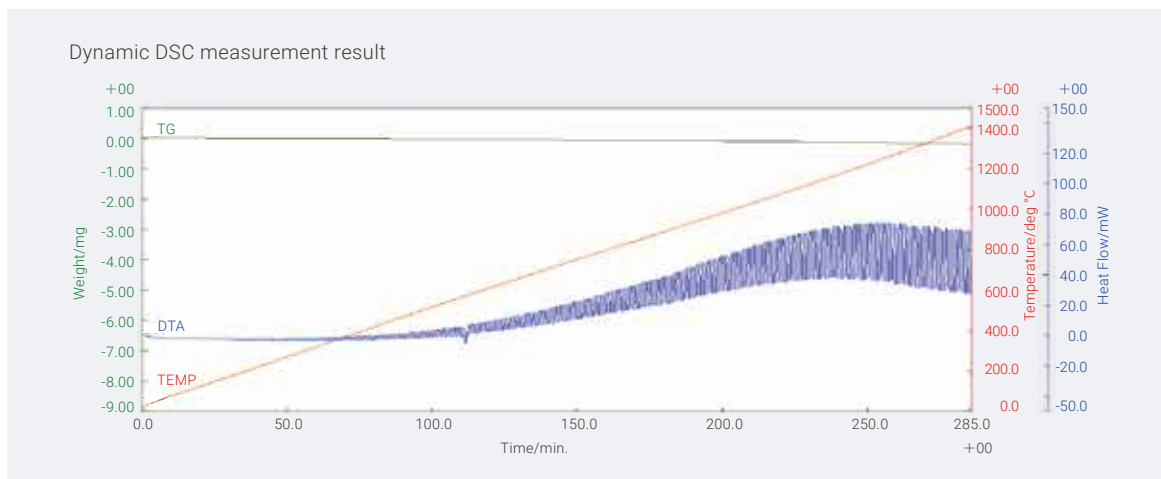

Analysis



Quartz is known to undergo a phase transition from α -quartz to β -quartz at elevated temperatures under ambient pressure: α -quartz \rightarrow 573° C \rightarrow β -quartz
The Dynamic DSC function in TG-DTA/DSC systems enables Cp measurement over a wide temperature range that is difficult to achieve using conventional DSC methods.



Maximum heating/cooling rate	20° C/min
Temperature amplitude	0.02° C to 5° C (setting resolution: 0.01° C)
Modulation period	40 s*2 to 200 s (setting resolution: 1 s)
Temperature range	According to furnace specifications

*1 Maximum temperature depends on the furnace specifications

*2 Minimum modulation period setting is 5 seconds

Dynamic TG: sample-controlled thermogravimetric analysis (SCTG)

The sample's rate of mass change is used as a parameter for controlling temperature. Two measurement modes with different control methods can be selected, namely Constant Reaction Control (CRC) and Stepwise Isothermal Analysis (SIA).

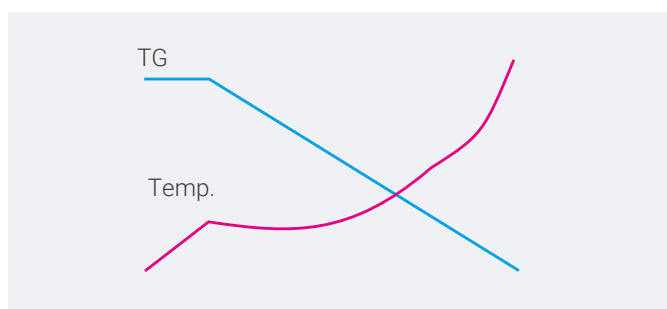

Constant Reaction Control (CRC)

To achieve a constant DTG, the temperature is controlled automatically, and temperature decrease is also controlled. CRC is suitable for investigating reaction mechanisms, reaction-kinetic analysis and reaction simulation. This method also allows predicting the measurement duration.

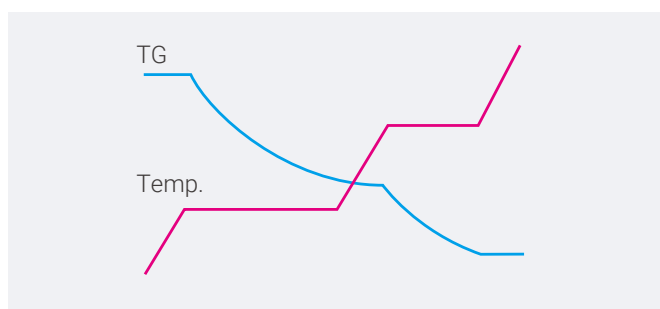

Stepwise Isothermal Analysis (SIA)

The temperature is increased at a constant rate. When DTG exceeds the preset value, isothermal control starts automatically. When DTG is below the preset value, the temperature is increased at a constant rate. This sequence is repeated until the reaction ends.

In the conventional constant-rate heating method, the temperature is raised according to the temperature program during reaction. Hence, if multiple reactions occur continuously, the decrease in mass appears overlapped (Fig. 2: constant-rate heating). In the dynamic TG method, the temperature is controlled according to the mass loss rate without performing forcible temperature increase and ignoring the sample's reaction (Fig. 1).

Through this method, we can obtain data with improved separation of reactions and resolution compared to the conventional constant-heating rate method (Fig. 2).

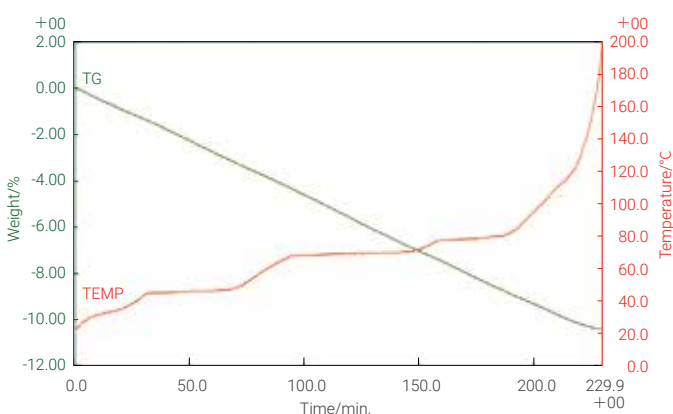

Figure 1: Dynamic TG (CRC method) measurement results for cyclodextrin Mass decrease rate: 0.03%/min

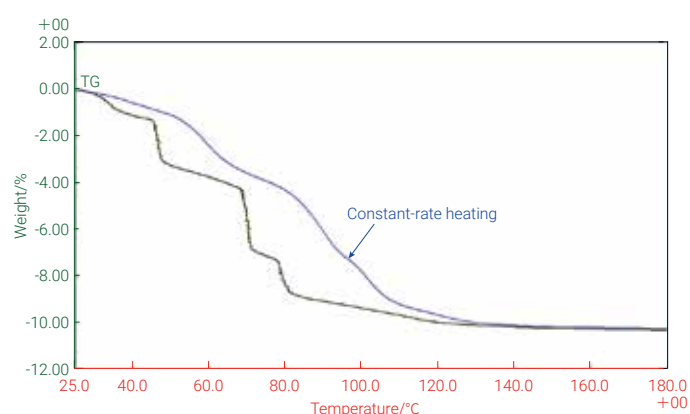

Figure 2: Comparing cyclodextrin measurement results of constant-rate heating method and dynamic TG method (abscissa axis is temperature)

※ Sample-controlled Thermo gravimetry

Optional Attachment / Unit

Evolved gas measurement

GC-MS Interface

A powerful tool for advanced material development and quality control, allowing simultaneous acquisition of thermal and evolved gas data. This interface supports integration with mass spectrometers and GC-MS systems from various manufacturers. Gas analysis can be performed alongside thermal measurements, and sample observation furnaces are also supported.



FTIR Interface

Thermal analysis provides temperature data, but not gas composition. By connecting an STA with an FTIR via this interface, STA-FTIR measurements enable qualitative analysis of gases evolved by decomposition or volatilization and their temperature correlation.



SPME Attachment

Solid Phase Micro Extraction (SPME) allows for qualitative gas analysis during STA without the need for a direct interface with a GCMS system. Gases can be extracted easily using SPME fibers for simplified evolved gas analysis.

SPME requires no complex equipment and is effective for extracting samples from solids, liquids, or gases. In a temperature range where mass loss is observed, a needle is inserted into the TG exhaust port to collect gas using the SPME fiber. The fiber is then introduced into a GCMS injection port, and the collected gases are separated and analyzed via GC to identify reaction products.



Optional Attachment / Unit

Flow meter

The flow meter controls the flow rate of the atmospheric gas (inert gas, air, etc.) supplied in the sample chamber.

Three models with 200, 500 and 1,000 mL/min F.S. are available.



Gas selector

The gas selector links to the measurement program and switches the internal valves to control the gas flowing into the sample chamber.

Note: Two flow meters are required separately.



Multi gas controller

The flow rate can be programmed in synchronization with the temperature program. Up to four different gases can be freely selected and changed as required.

Compatible instrument: STAvesta



2ch-FLOW COMPO Jr.

Enables gas flow, flow rate setting and switching of gases with precision specified in the measurement program. Gas types and full scale can be selected.



Oxygen-reducing set

This kit enables rapid reduction of residual oxygen concentration by flowing inert gas through the system. An included air pump also allows airflow when required.

Tabletop vibration isolation table

Ideal for conducting STA measurements in places with high levels of vibration.



Automatic Sample Changer (ASC)

The automatic sample changer enables up to 1,000 consecutive measurements by automatically replacing sample pans. This significantly contributes to automation and high-throughput analysis.

The sample tray section, where samples are placed, comes standard with a gas-flow design. During standby, gas can be flowed over the sample area to minimize contact with the atmosphere. This feature is particularly effective for moisture-sensitive powder samples, ensuring more reliable measurement results.

ASC Safety Cover

A standard accessory, this safety cover is designed to reduce mechanical hazards associated with the operation of the automatic sample changer. An electromagnetic lock prevents the cover from being opened during ASC operation or active measurement, thereby preventing accidental contact with moving components.

ASC Safety Full Cover

This optional full cover provides additional protection by enclosing not only the ASC but also the furnace drive mechanism. It minimizes overall system risks, including pinch-point hazards and contact with heated or moving parts.



Specifications and Utilities

Specification

Model name	Thermo plus EV03						Thermo plus EV02
	STAvesta						TG-DTA8122
	Sample observation	Standard	High temperature	Indirect heated	Refrigerated cooling	High concentrate water vapor	TG-DTA with Separate controller
	C	S	H	B	LR	HUM	
Measurement temperature range	Room temperature to 1,100° C ^{*1}	Room temperature to 1,100° C	Room temperature to 1,500° C	Room temperature to 1,500° C	-40° C to 700° C	Room temperature to 1,400° C	Room temperature to 1,500° C
Heating rate (Max)	100°C/min			50°C/min	20°C/min	20°C/min	100°C/min
Balance system	Horizontal differential triple coil balance system						
Sample amount (Max)	1 g (90 µL)						
TG range	±500 mg						±250 mg
DSC range	±600 mW (100°C), ±1,400 mW (1,000°C), ±3,000 mW (1,500°C)						
DTA range	±1,000 µV						
TG sensitivity / noise level (RMS) ^{*2}	0.18 µg/0.09 µg						—
DSC sensitivity / noise level (RMS) ^{*2}	10 µW/5 µW						—
Temperature accuracy ^{*2}	±0.2°C				—	—	—
Energy precision (σ/ave.) ^{*2}	±1%				—	—	—
Temperature precision (σ) ^{*2}	±0.05°C				—	—	—
Specific heat precision ^{*2}	—	±3%		—	—	—	—
TG baseline drift volume ^{*2}	<10 µg (up to 1,000° C), <20 µg (up to 1,400° C)				—	—	—
Measurement atmosphere	Air, inert gas, vacuum ^{*3}				Dry gas (Simulated air, inert gas N ₂ , Ar, He)	Inert gas (N ₂), humid atmosphere	Air, inert gas, vacuum ^{*3}
Isothermal unit	Not compatible	Option			Not compatible	Not compatible	Not compatible
Self-diagnostic function	Yes						No
Blank auto-adjustment function	Yes						No
ASC ^{*4}	Automatic sample changer (Sample: 52, reference: 3, calibration sample: 5)						
ASC safety cover	Standard accessory						—

*1 For sample observation measurement: up to 1,000° C *2 Under Rigaku's condition *3 Not compatible with ASC measurement *4 Option

Model	HUM-1
Humidity generation method	Bubbling bath/dry gas combination method
Humidity range	Room temperature to 80° C, dry to 90% RH
Gas	Dry N ₂
Humidity sensor	Polymer type relative humidity sensor
Temperature measurement element	Pt resistance temperature sensor
Duration for continuous humidity	100 hours at 60° C, 90% RH, 40 hours at 80° C, 90% RH

Utility

STAvesta	Single phase 100-240 VAC, 50/60 Hz, 15 A, grounded 1-socket outlet
Refrigerated cooling unit	Single phase 100 VAC, 50/60 Hz, 15 A, grounded 1-socket outlet
HUM unit	Single phase 100 VAC, 50/60 Hz, 5 A, grounded 1-socket outlet
TG-DTA with Separate controller	Single phase 100-240 VAC, 50/60 Hz, 15 A, grounded 1-socket outlet

Current value is the maximum current rating when connected to the 100 V power source.

Dimensions

STAvesta

Mass : 45 kg

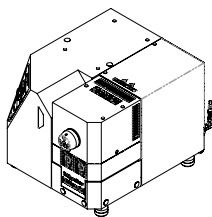

W412×D561×H355 mm

STAvesta/C (Sample observation)

Mass : 47 kg

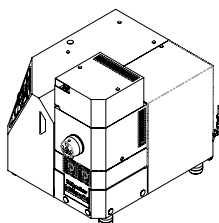

W412×D561×H456 mm

STAvesta/HUM

Mass : 50 kg
 (HUM-1)
 Mass : 15 kg

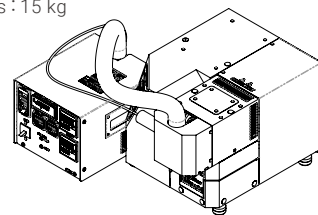

W412×D621×H355 mm
 (HUM-1) W290×D350×H260 mm

STAvesta+ASC

Mass : 55 kg

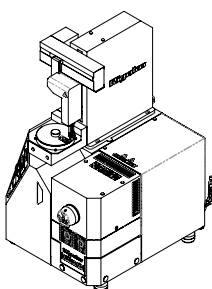

W412×D561×H705 mm

STAvesta/C+ASC

Mass : 57 kg

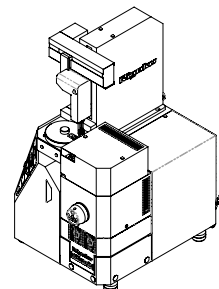

W412×D561×H705 mm

STAvesta/LR

Mass : 50 kg
 (Refrigerator)
 Mass : 61 kg

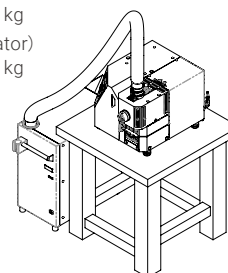

W412×D601×H422 mm
 (Refrigerator) W295×D500×H570 mm

STAvesta+ ASC safety cover

Mass : 61 kg

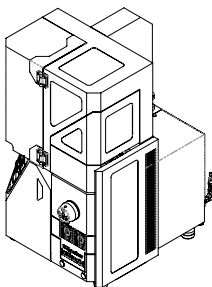

W435×D561×H727 mm

STAvesta+ ASC safety full cover

Mass : 65 kg

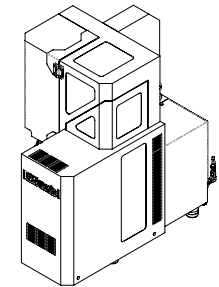

W434×D720×H727 mm

TG-DTA with Separate controller

Mass : 31 kg (Main unit 18 kg, Control unit 13 kg)

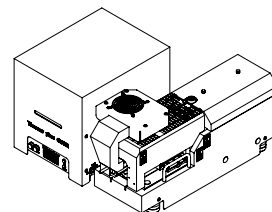

Main unit W208×D625×H299 mm
 Control unit W275×D355×H318 mm

*The performance figures presented in this catalog represent test results obtained by Rigaku Corporation and Rigaku does not guarantee that identical results will be consistently achieved under different environmental and operating conditions.

*"STAvesta" is trademark or registered trademark of Rigaku Corporation or its affiliates.

*Company names and product names mentioned in this site are generally trademarks or registered trademarks of their respective companies.